

GMCC TOSHIBA



Toshiba R22	Desplazamiento	Capacidad			Consumo	COP	Altura	Capacitor	Cañería de descarga	Cañería de succión	Alimentación Eléctrica	Aceite		Térmico
	(cm ³ /rev)	(W)	(Btu/h)	(Frig.)	(W)	(W/W)	(mm)	(uF/V)	(mm)	(mm)	(V-F-Hz)	Tipo	ml	
PH165X1C-4DZDE2	16.5	2810/2840	9582/9684	2250	920/950	3.05/2.99	285	25/370	8.2	9.8	220v-1F-50Hz	Mineral	400	Externo
HSM215V3UDZ	21.4	3700/3750	12624/12727	3000	1225/1300	302/288	300	35/370	8.1	9.8	220v-1F-50Hz	Mineral	300	Interno
PH310G2C-4KU1	30.8	5515/5540	18818/18903	4500	1695/1775	325/312	310	55/400	9.8	12.9	220v-1F-50Hz	Mineral	620	Interno
PH420G2CS-4KU1	42.3	7420/7460	25302/25317	6000	2390/2525	310/295	354	50/400	9.8	12.9	220v-1F-50Hz	Mineral	850	Interno

Compresores Toshiba R22

PH165X1C-4DZDE2

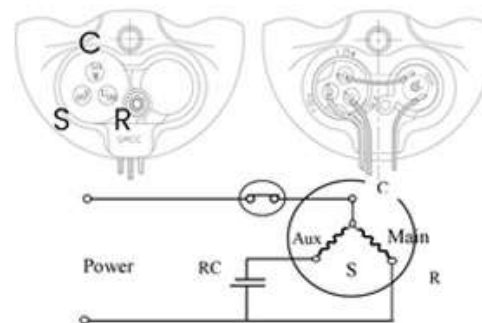
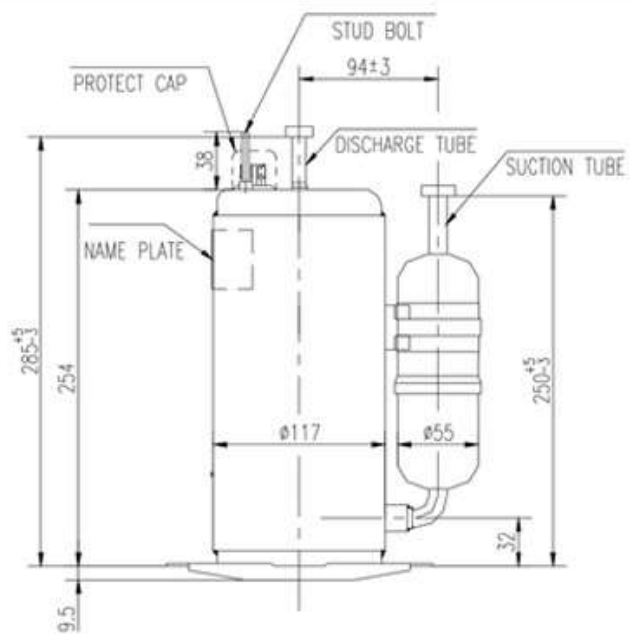

- S:** Arranque
- R:** Trabajo
- C:** Línea
- RC:** Capacitor de Arranque
- OLP:** Protector Térmico
- IOL:** Protector Térmico interno